



T. S. PUMPS AND VALVES PVT. LTD.

FORGED BALL VALVE

CLASS: 800

Features

Three Piece fire safe design, molded PTFE seat, Anti blow out stem, Antistatic, wide variety of seat and seal materials, ISO 5211 top flange mountings.



Design Standard : BS EN ISO 17292
Testing Standard : API 598/ EN 12266-1

Test Pressure in Bar

		Class	800
Hydro Test	Shell		211
	Seat/ Back Seat		152
Air Test	Seat		07

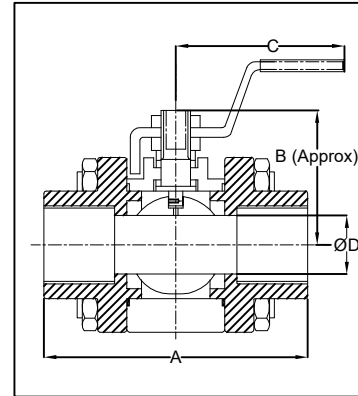

Class - 800

Size		A		B (Approx.)		C	ØD	
mm	in	FB	RB	FB	RB		FB	RB
15	1/2	68	68	70	70	150	13	13
20	3/4	82	68	85	70	180	19	13
25	1	98	82	90	85	180	25	19
32	1 1/4	109	98	100	90	180	32	25
40	1 1/2	122	109	120	100	200	38	32
50	2	---	122	---	120	200	---	38

FB =Full Bore RB =Reduced Bore

All Dimensions are in "mm"

MATERIALS

Body & End Piece	ASTM A105, ASTM A182 Gr. F304 / F316
Ball	ASTM A 276 TYPE 304 / 316, ASTM A 351 Gr. CF8/ CF8M
Body Seal	PTFE / SPW 304 Grafoil
Seats	PTFE / GFT / CFT
Stem / Gland	ASTM A 276 SS 410 / SS 304 / SS 316
Stem Packing	PTFE / GFT
Gland Packing	PTFE
Fasteners	ASTM A193 Gr. B7 / ASTM A 194 Gr. 2H
Lever	MS with PVC Sleeve

NOTE:

- Please specify flow medium, working pressure, temperature & service conditions.
- Other materials not mentioned above & higher sizes are available on request
- Face to Face as per Manufacturer Standard
- End Connections of Socket Weld End as per ASME B 16.11, Screwed End as per ASME B 1.20.1 (NPT) & BS 21 (BSP & BSPT)
- Butt Weld End as per ASME B 16.25
- Valves can be supplied with IBR.
- In process of continuous improvement of products, the data given here in is subject to change

T.S. PUMPS & VALVES PVT.LTD.

B-490, Industrial Estate, Gokul Road,
Hubballi-580030, Karnataka, INDIA
Phone : +91-836-2331096 / 2210615
Email : sales@tsvalvesindia.com
Website : www.tsvalvesindia.com



TSPV: CAT-007/R-01
Date : 02/06/2017